

GENERAL CHARACTERISTICS -

	320	240	125
Bore	76mm	70.6mm	54mm
Stroke	61mm	61mm	54mm
Displacement	276.6cc	237.9cc	123.7cc
Carburetor	26mm Dell'orto	26mm Dell'orto	22mm Dell'orto
Wheelbase	52 inches	52 inches	51 inches
Ground Clearance	12.8 inches	12.8 inches	12.3 inches
Tank Capacity	1.06 gallons *	1.06 gallons *	1.06 gallons *
Timing	2.6 - 2.8mm BTDC	2.3-2.5mm BTDC	1.9-2.1mm BTDC
Plug	Champion N12-Y .026"	Champion N12-Y .026"	Champion N12-Y .024"

*1.5 Gallons with optional MW tank

LUBRICATION -

SWM recommends that only a mix ratio of 50:1 be used. Use this from the start-up of your engine - don't use a heavier oil mix during break in. Experience has proven that the jetting will be almost perfect if you use 50:1 ratio. We strongly recommend that you use SWM TOTAL 2T. We have had outstanding success with this product.

BREAK-IN -

As with any new machine, care must be taken to avoid engine damage when new. We recommend that at least three (3) tankfuls of fuel be run through the engine before undertaking high speed operation. Unlike many bikes, the SWM engine does not "loosen up" but tends to remain smooth and crisp from the very beginning.

CARB & JETTING -

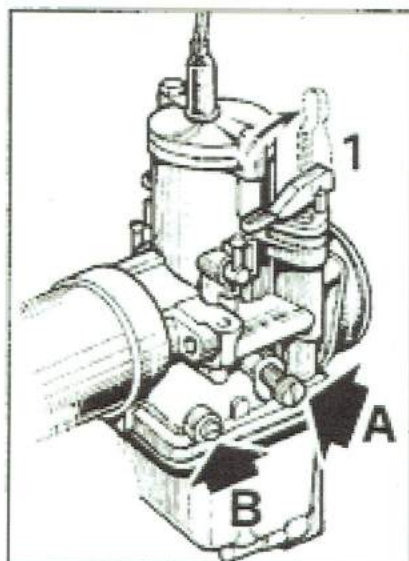

- A - Idle Speed
- B - Idle Mixture (see note)
- 1 - Choke (lift for choke)